

ASSEMBLY

- In factory
- On site

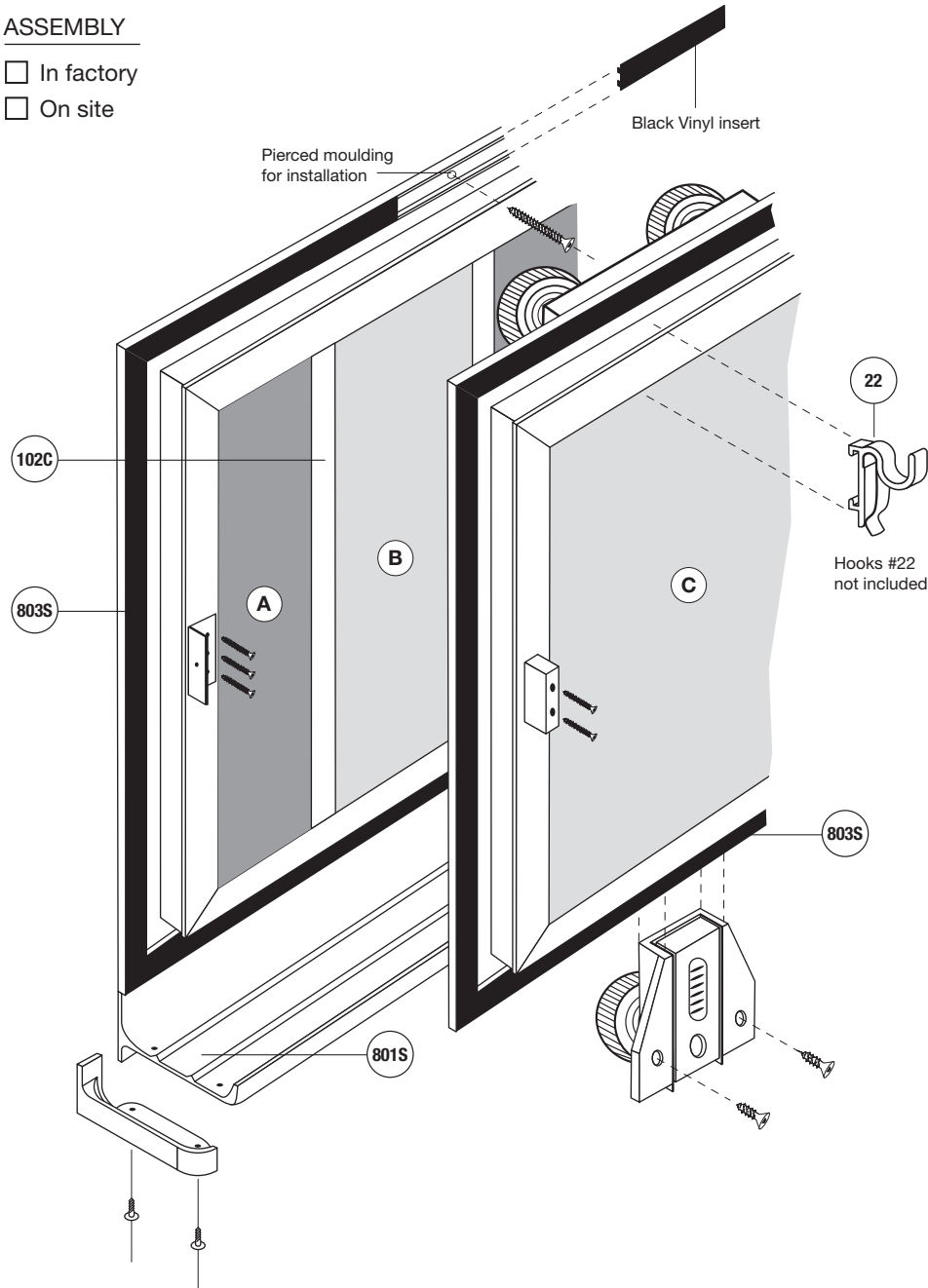

Dimensions

Type : _____

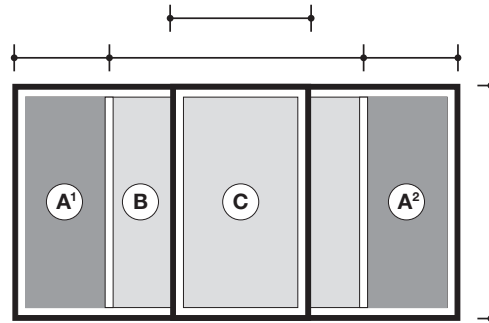

- A¹ Width: _____ C Width: _____
- B Width: _____ Total Height: _____
- A² Width: _____ Total Width: _____

Location:

Moulding

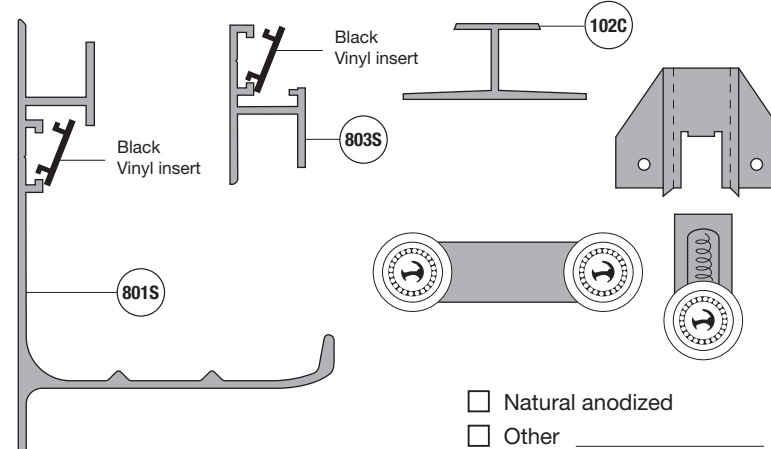

Mechanical joint

Surface display of more than 12 feet only.



8500

QUANTITY : _____

Surfaces and colors

- Lauzonite white, green, black or grey
- Laminate white, grey or black
- Porcelain white, green or black
- Natural cork 1/4, 1/8, 1/32
- Colored cork 12 colors available
- Fabric
- Velcro
- Other

To visualize the colors please consult our website at www.cctn.com

Surfaces **A** _____
Surface **B** _____
Surface **C** _____

Hooks (not included)

Type #22 Quantity: _____

Notes :

Contractor:

Architect:

Project:

Address: