

**ASSEMBLY**

- In factory
- On site

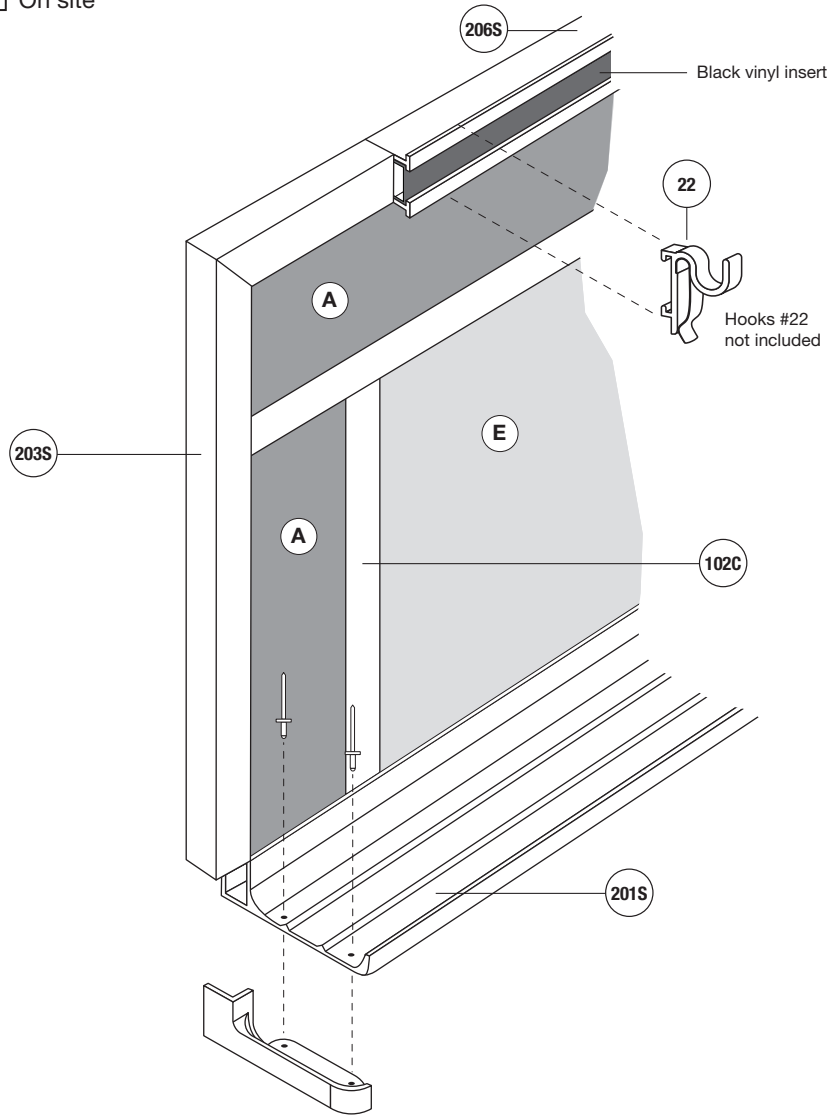

**Dimensions**

Type : \_\_\_\_\_

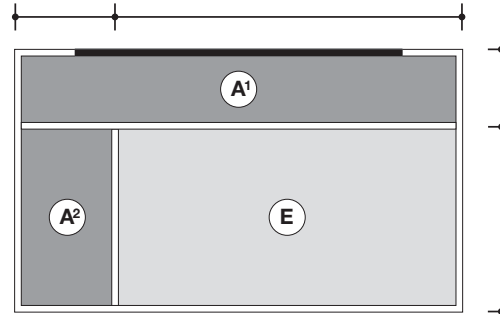

- A** Display
- E** Writing

**A<sup>1</sup>** Height: \_\_\_\_\_ **E** Width: \_\_\_\_\_  
**A<sup>2</sup>** Height: \_\_\_\_\_ **A<sup>2</sup>** Width: \_\_\_\_\_  
 Total Height: \_\_\_\_\_ Total Width: \_\_\_\_\_

**Location:**

**Moulding**

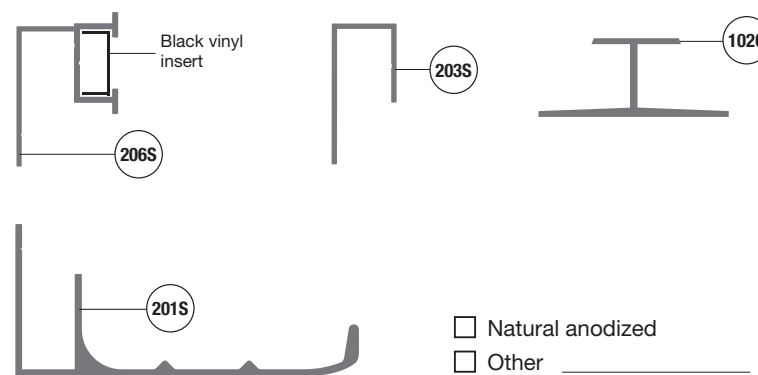

**Mechanical joint**

Surface display of more than 12 feet only.



**2000**

QUANTITY : \_\_\_\_\_

**Writing surface (E)**

- Lauzonite     white     green     black     grey
- Laminite     white     grey     black
- Porcelain     white     green     black

**Display surface (A)**

- A<sup>1</sup>**  **A<sup>2</sup>**  Natural cork     1/4     1/8     1/32
- Colored cork: \_\_\_\_\_
- Fabric: \_\_\_\_\_
- Velcro: \_\_\_\_\_
- Other: \_\_\_\_\_

**Hooks (not included)**

- Type #22    Quantity: \_\_\_\_\_

**Notes :**

**Contractor:**

**Architect:**

**Project:**

**Address:**